

TCD 2011

The Engine for Construction Equipment.
23 – 74,9 kW | 31 – 100 hp at 1600 – 2800 rpm



The engine company.



Engine description

Type of cooling:	Oil-cooled, thermostatically controlled, with conventional or optional with integrated cooling system on D 2011 L2 / I, L3 / I, L4 / I und TD 2011 L4 / I engines. Water-cooled, water circulation pump driven by V-belt, thermostat and integrated bypass system on D / TD / TCD 2011 L4 W.
Crankcase:	Ribbed, thin-wall grey cast iron, noise-optimized.
Crankcase breather:	Closed-circuit breather.
Cylinder head:	Cast iron bloc cylinder head.
Valve arrangement/ Timing:	Overhead valves in cylinder head, two valve per cylinder, actuated via rocker arms, push rods and tappets, driven by tooth-belt and camshaft.
Charging:	One turbo charger on TD 2011 engines, plus charge air cooling on TCD 2011.
Piston:	Three-ring piston, two compressions rings and one oil scraper ring.
Piston cooling:	Oil jet.
Connecting rod:	Drop-forged steel rod, fracture split.
Crankshaft:	Casted, made from high grade SG iron with cast-on counterweights, fillet-rolled.
Crankshaft and big end bearings:	Three metal shell bearings.
Camshaft:	Steel, with cams for fuel injection pumps and fuel lift pump.
Lubrication system:	Circulating forced lubrication, tooth-belt-driven lubricating oil rotor pump.
Lube oil cooler:	Integrated in the oil filter bracket on water-cooled engines.
Lube oil filter:	Full flow spin-on cartridge filter.
Fuel injection system:	Direct-injection.
Injection nozzle:	Multi hole nozzle.
Injection pump/ Governor:	Unit pump system, mechanical governor in front-cover integrated for fixed and variable speed.
Fuel lift pump:	Piston pump.
Fuel lift filter:	Replaceable cartridge with water trap.
Alternator:	Three-phase alternator, 14 V / 50 A (Standard).
Starter motor:	12 V / 2.3 kW.
Options:	Intake manifold connections, exhaust manifolds connections, hydraulic pumps drives, engine mounts, multi oil pan drains, dipsticks, SAE 4/5 flywheel housings, fly wheels, oil filter position horizontal, vertical and remote, oil filler in cylinder head cover and low level fill on side of crankcase, motor electric 12 V and 24 V, electronic governing.

Characteristics

2-, 3-, 4-Cylinder natural aspirated and 4-Cylinder turbocharged in-line engines | Oil-cooled | Optional with integrated cooling system | 4-Cylinder natural aspirated, also turbo-charged and turbo-charged with charge-air-cooling | Water-cooled | Compact engine design | Advanced fuel injection and combustion system | Full line customized options | Cold starting ability for extreme climatic conditions | Full power at flywheel end for axial or radial drives | Optional PTO for hydraulic pumps up to 28 kW | All service points on one engine side.

Your benefits

- Compact engine, for low cost and space saving installations.
- Competitive power to weight ratio.
- Low exhaust emissions meeting EU-Nonroad 2004/26/ EG Stage III A and US-EPA Tier 3 Nonroad.
- Simple design with high reliability.
- Long maintenance intervals reducing after sales cost for your customers.

air-/ oil-cooled with integrated cooling system

Engine type		D 2011 L2 I	D 2011 L3 I	D 2011 L4 I	TD 2011 L4 I
Number of cylinders		2	3	4	4
Bore/stroke	mm inch	94/112 3.7/4.41	94/112 3.7/4.41	96/125 3.78/4.92	96/125 3.78/4.92
Displacement	l cu inch	1.55 95	2.33 142	3.62 221	3.62 221
Compression ratio		19:1	19:1	19:1	18:1
Rated speed	rpm	2800	2800	2600	2600
Mean piston speed	m/s ft/m	10.5 2058	10.5 2058	10.8 2133	10.8 2133

EU Stage III A / US-EPA Tier 3 Power ratings for mobile construction machines¹⁾

		D 2011 L2 I	D 2011 L3 I	D 2011 L4 I	TD 2011 L4 I
Power to ISO 14396	kW hp	23 31	36 49	48 62	58 77
at engine speed	rpm	2800	2800	2600	2600
Mean effective pressure	bar psi	6.3 91	6.7 97	5.9 86	7.4 107
Max. torque	Nm ft lb	90 66	137 101	190 140	240 177
at engine speed	rpm	1700	1700	1700	1600
Minimum idle speed	rpm	900	900	900	900
Specific fuel consumption ²⁾	g/kWh lb/hph	222 0.36	222 0.36	220 0.36	235 0.39
Weight to DIN 70020, Part 7A ³⁾	kg lb	175 ³⁾ 386 ³⁾	217 ³⁾ 478 ³⁾	270 ³⁾ 595 ³⁾	267 ³⁾ 589 ³⁾

Dimensions

		D 2011 L2 I	D 2011 L3 I	D 2011 L4 I	TD 2011 L4 I
Length (A)	mm inch	487 19.2	599 23.6	710 28.0	710 28.0
Width (B)	mm inch	451 17.8	451 17.8	467 18.4	530 20.9
Height (C)	mm inch	683 26.9	678 26.7	713 28.1	713 28.1

external oil-cooled

	D 2011 L2	D 2011 L3
Number of cylinders	2	3
Bore/stroke	94/112 3.7/4.41	94/112 3.7/4.41
Displacement	1.55 95	2.33 142
Compression ratio	19:1	19:1
Rated speed	2800	2800
Mean piston speed	10.5 2058	10.5 2058

Power to ISO 14396	kW hp	24 32	37 49
at engine speed	rpm	2800	2800
Mean effective pressure	bar psi	6.5 94	6.7 97
Max. torque	Nm ft lb	93 69	140 103
at engine speed	rpm	1700	1700
Minimum idle speed	rpm	900	900
Specific fuel consumption ²⁾	g/kWh lb/hph	224 0.37	224 0.37
Weight to DIN 70020, Part 7A ³⁾	kg lb	169 ⁴⁾ 373 ⁴⁾	210 ⁴⁾ 463 ⁴⁾

Length (A)	mm inch	408 16.1	599 23.6
Width (B)	mm inch	451 17.8	451 17.8
Height (C)	mm inch	683 26.9	678 26.7

external water-cooled

	D 2011 L4 W	TD 2011 L4 W	TCD 2011 L4 W
Number of cylinders	4	4	4
Bore/stroke	96/125 3.78/4.92	96/125 3.78/4.92	96/125 3.78/4.92
Displacement	3.62 221	3.62 221	3.62 221
Compression ratio	19:1	18:1	18:1
Rated speed	2600	2600	2600
Mean piston speed	10.8 2133	10.8 2133	10.8 2133

Power to ISO 14396	kW hp	50 67	68 91	74.9 100
at engine speed	rpm	2600	2600	2600
Mean effective pressure	bar psi	6.4 93	8.7 126	9.6 139
Max. torque	Nm ft lb	210 155	280 207	350 258
at engine speed	rpm	1700	1600	1600
Minimum idle speed	rpm	900	900	900
Specific fuel consumption ²⁾	g/kWh lb/hph	220 0.36	216 0.36	208 0.34
Weight to DIN 70020, Part 7A ³⁾	kg lb	270 ⁴⁾ 595 ⁴⁾	269 ⁴⁾ 589 ⁴⁾	269 ⁴⁾ 571 ⁴⁾

Length (A)	mm inch	710 28.0	710 28.0	710 28.0
Width (B)	mm inch	467 18.4	495 20.0	495 19.5
Height (C)	mm inch	713 28.1	713 28.1	713 28.1

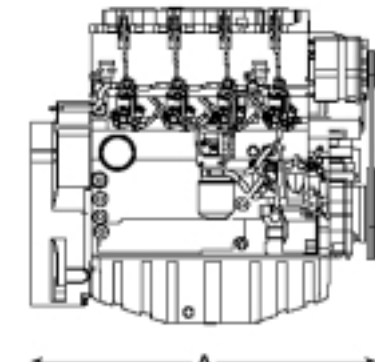
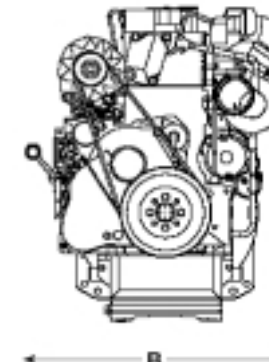
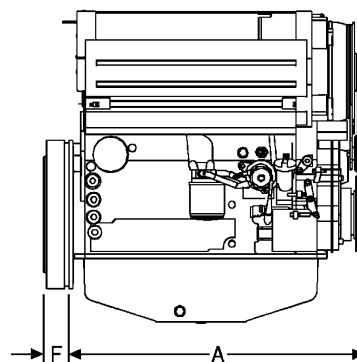
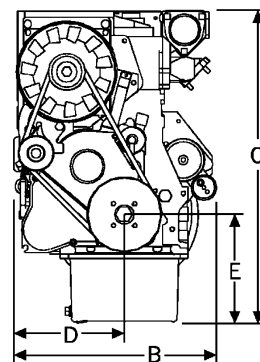

- 1) Power ratings at flywheel gross, without cooling system.
- 2) At optimal operating point. Specific fuel consumption based on diesel fuel with a specific gravity of 0.835 kg/dm³ at 15°C (6.96 lb/US gallon at 60°F).
- 3) Incl. integrated cooling system, flywheel and SAE-housing, but without starter motor, alternator, dry weight.
- 4) Incl. flywheel and SAE-housing, but without starter motor, alternator, dry weight.

The values given in this data sheet are for information purposes only and not binding.
The information given in the offer is decisive.

Standard engines

Engine D 2011 L2 | D 2011 L2 I

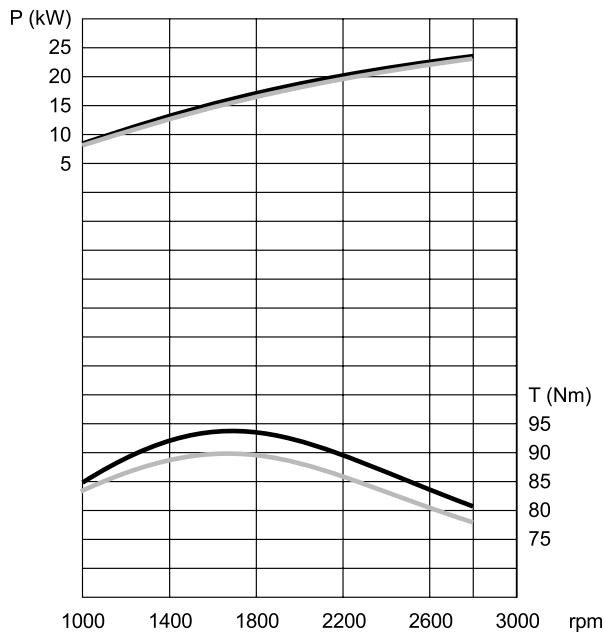

Engine D 2011 L3 | D 2011 L3 I

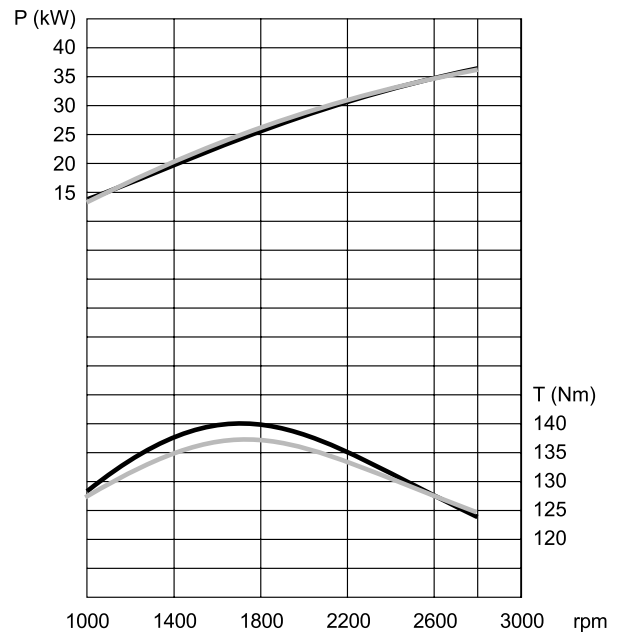

Engine D 2011 L4 I

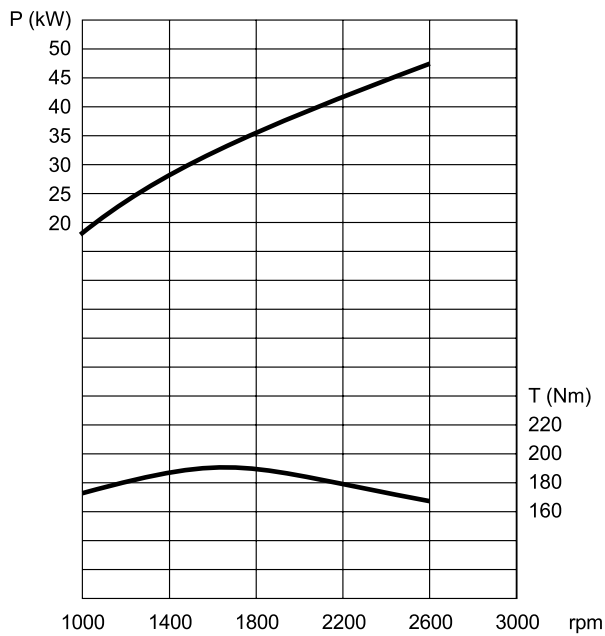

Engine TD 2011 L4 I

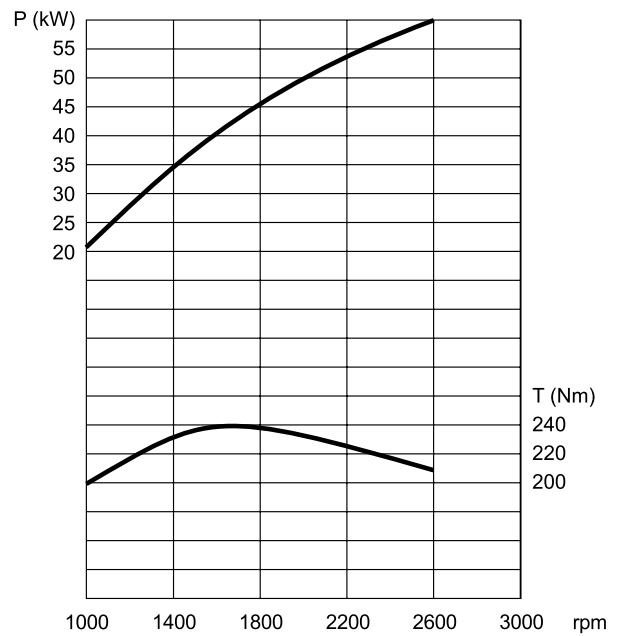

Standard engines

Engine D 2011 L4 W

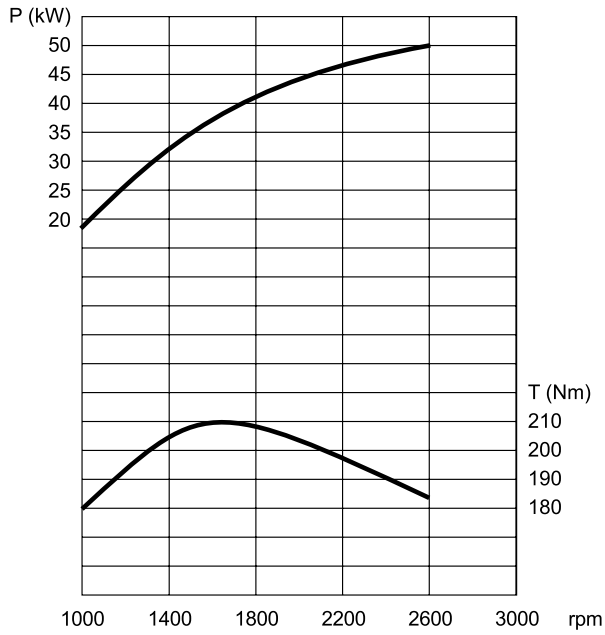

Engine TD 2011 L4 W

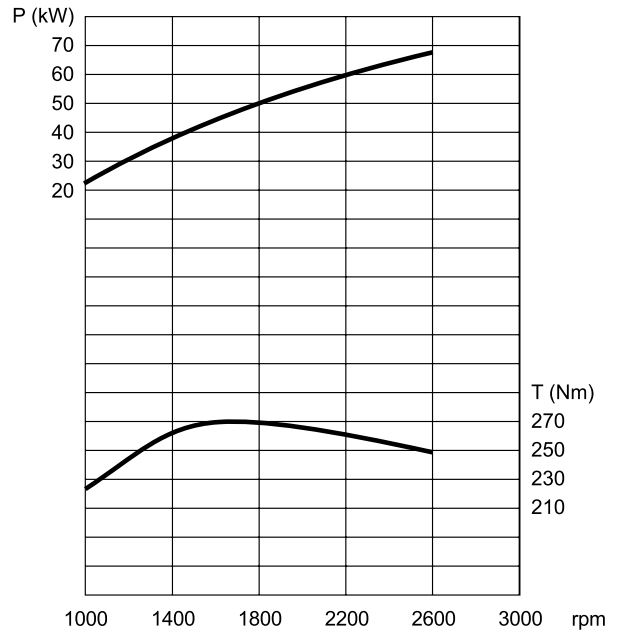

Engine TCD 2011 L2 W

