

TD 2009

The Engine for Construction Equipment.
28 – 50 kW | 38 – 67 hp at 1600 – 3000 rpm

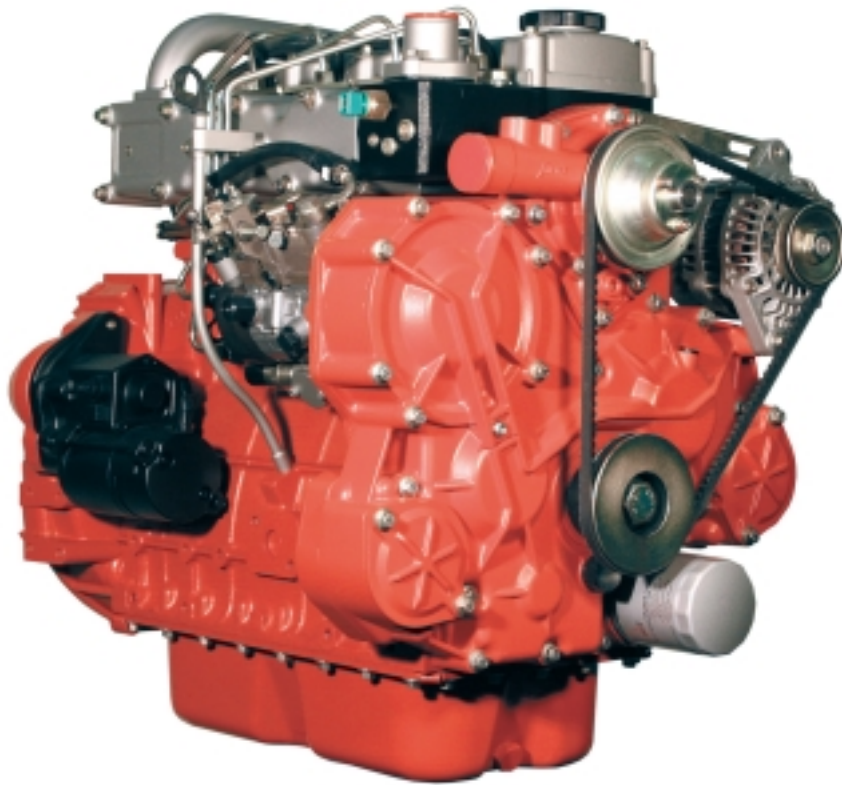

The engine company.



Engine description

Type of cooling:	Water-cooled, water circulation pump driven by V-belt, thermostat and integrated bypass system.
Crankcase:	Ribbed, thin-wall grey cast iron, noise-optimized.
Crankcase breather:	Closed-circuit breather.
Cylinder head:	Cast iron cross flow cylinder head with separate aluminum inlet manifold.
Valve arrangement/ Timing:	Overhead valves in cylinder head, two valves per cylinder, actuated via hydraulic tappets, push rods and rocker arms, driven by low-noise helical cut gears with "Anti Backlash Gear" and camshaft.
Charging:	None at 3- and 4-cyl. N/A engines / One turbo charger at the TD 2009 L4.
Piston:	Three-ring piston, two compressions rings and one oil scraper ring.
Piston cooling:	N/A engines splash oil-cooled / TD 2009 L4 with oil jet.
Connecting rod:	Drop-forged steel rod
Crankshaft and big end bearings:	Bi-metal shell bearings
Crankshaft:	3-Cyl. casted, made from high grade SG iron / 4-Cyl. made from drop-forged steel.
Camshaft:	Chilled cast iron.
Lubrication system:	Gear driven lubricating oil pump.
Lube oil cooler:	Water-cooled, integrated in the lube oil filter console.
Lube oil filter:	Full flow spin-on cartridge filter.
Fuel injection system:	In-direct fuel injection (IDI) on N/A engines / Direct fuel injection (DI) on turbo charged engines.
Injection nozzle:	Pintle nozzle on IDI engines / Multi hole nozzle on DI engines
Injection pump/ Governor:	Rotary fuel injection pump, mechanical governing, fixed and variable speed.
Fuel lift pump:	Diaphragm pump.
Fuel filter:	Replaceable cartridge with water trap.
Alternator:	Three-phase alternator, 14 V / 50 A (Standard).
Starter motor:	12 V / 2.0 kW.
Options:	Intake manifold connections, exhaust manifolds connections, hydraulic pumps drives, engine mounts, multi oil pan drains, dipsticks, SAE 4/5 flywheel housings, fly wheels, oil filter position horizontal, vertical and remote, oil filler in cylinder head cover and low level fill on side of crankcase, motor electric 12 V and 24 V, electrical fuel lift pump, electronic governing.

Characteristics

3 and 4 cylinder naturally aspirated in-line engines | 4-cylinder also with turbo charging | Water cooled | Compact engine design | Advanced fuel injection and combustion system | Full line customized options | Cold starting ability for extreme climatic conditions | Full power at flywheel end for axial or radial drives | Two optional side PTOs from gear end cover

Your benefits

- Compact engine, for low cost and space saving installations.
- Competitive power to weight ratio.
- Low exhaust emissions meeting EU - Nonroad 2004/26/EG Stage III A and US - EPA Tier 3 Nonroad.
- Simple design with high reliability.
- Long maintenance intervals reducing after sales cost for your customers.

Engine model		D 2009 L3	D 2009 L4	TD 2009 L4
Number of cylinders		3	4	4
Bore/Stroke	mm inch	90/90 3.54/3.54	90/90 3.54/3.54	90/90 3.54/3.54
Displacement	l cu inch	1.72 105	2.29 140	2.29 140
Compression ratio		22 : 1	22 : 1	17 : 1
Max. rated speed	rpm	3000	3000	2800
Mean piston speed	m/s ft/m	9.0 1772	9.0 1772	8.4 1654

EU Stage III A / US - EPA Tier 3 Power ratings for mobile construction machines¹⁾

Power acc. to ISO 14396	kW hp	28 38	36 48	50 67
at engine speed	rpm	3000	3000	2800
Mean effective pressure	bar psi	6.5 95	6.3 91	9.4 136
Max. Torque	Nm ft-lb	106 78	146 108	200 148
at engine speed	rpm	1600	1600	1600
Minimum idle speed	rpm	900	900	900
Specific fuel consumption ²⁾	g/kWh lb/hph	240 0.39	235 0.39	220 0.36
Weight to DIN 70020, Part 7A ³⁾	kg lbs	180 397	205 452	220 485

Dimensions

in mm inch	A	B	C
D 2009 L3	597 23.5	490 19.3	612 24.1
D 2009 L4	680 26.8	490 19.3	612 24.1
TD 2009 L4	696 27.4	518 20.4	633 24.9

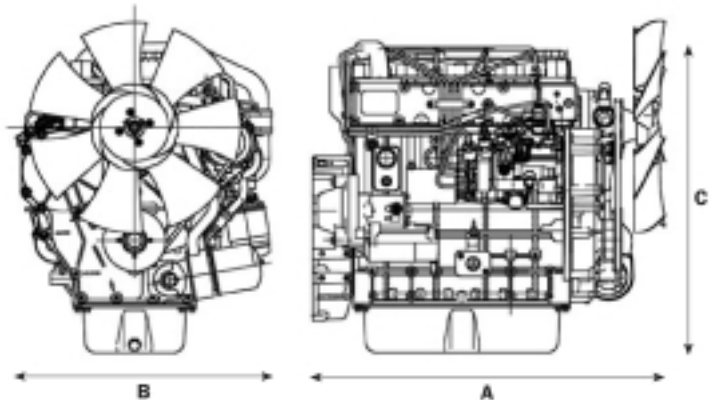

1) Power ratings at flywheel gross, without cooling system.

2) At optimal operating point. Specific fuel consumption based on diesel fuel with a specific gravity of 0.835 kg/dm³ at 15° C (6.96 lb/US gallon at 60° F).

3) Not including starter motor/alternator, radiator and operating fluids but including flywheel and flywheel housing.

The values given in this data sheet are for information purposes only and not binding.

The information given in the offer is decisive.

Standard engines

Engine D 2009 L3

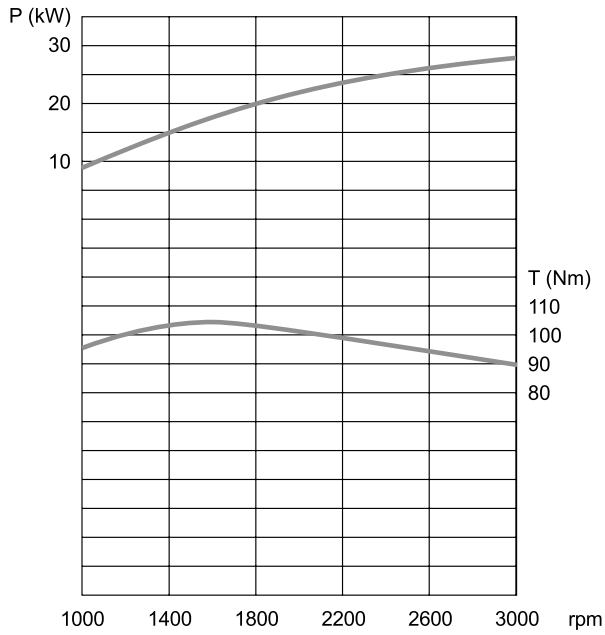

Engine TD 2009 L4

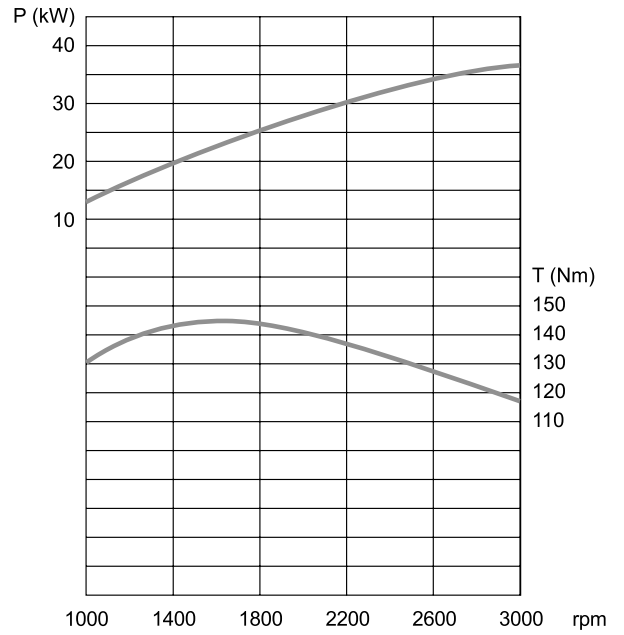

Engine TD 2009 L4

