

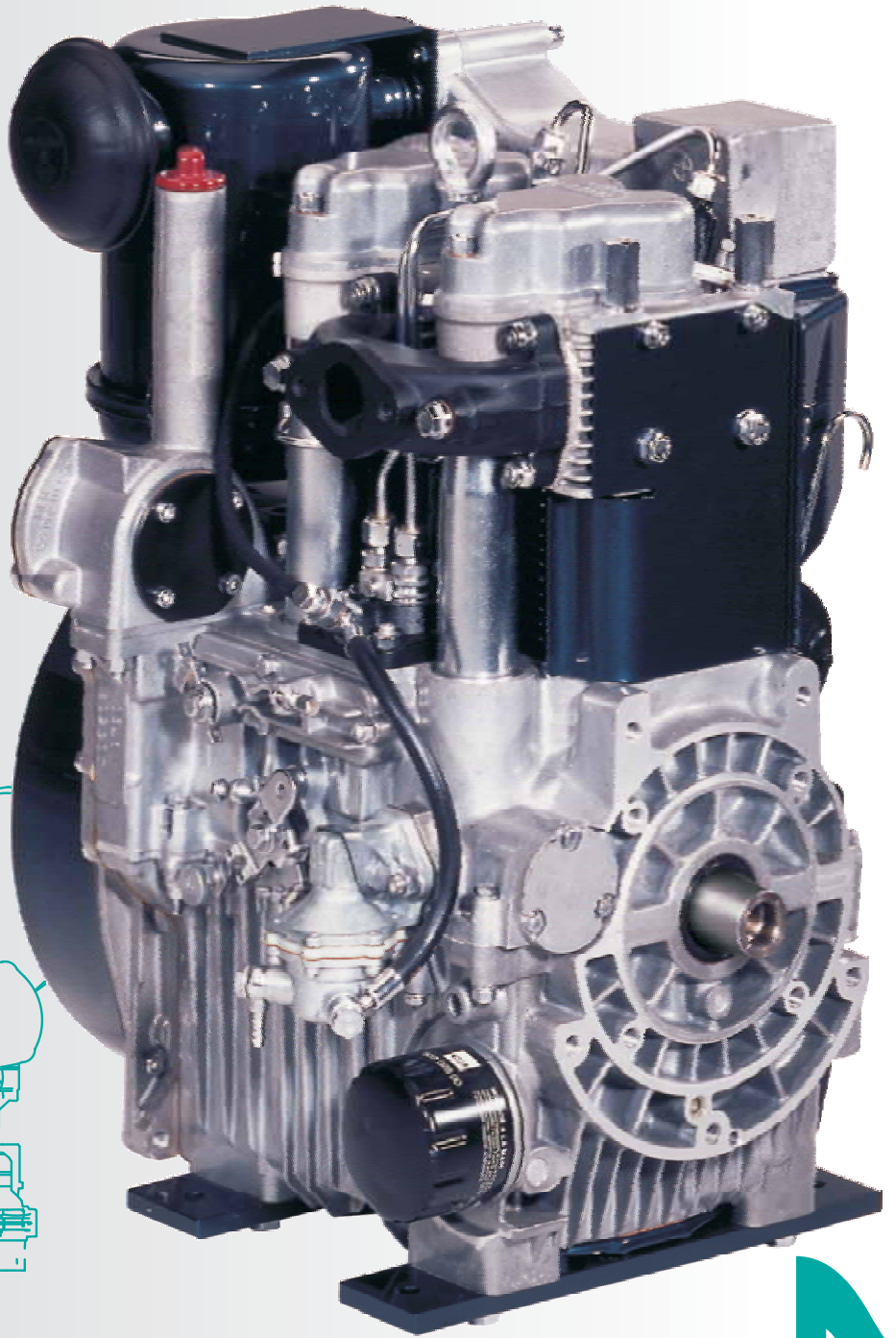

G Series

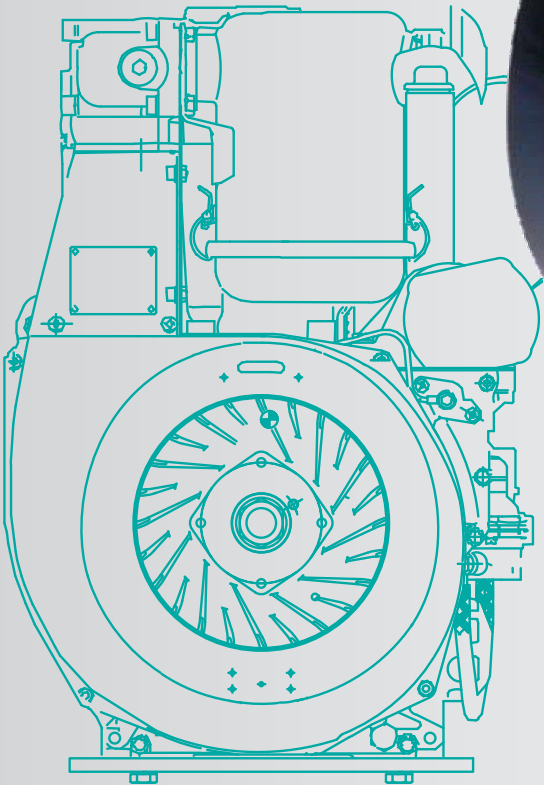

2G40 • 7.4 - 17.0 kW

THE 2-CYLINDER POWER PACKAGE

2G40

Exhaust reduced types on request

EPA II

EPA IV (2008)

CARB II

CARB IV (2008)

ECE-R24

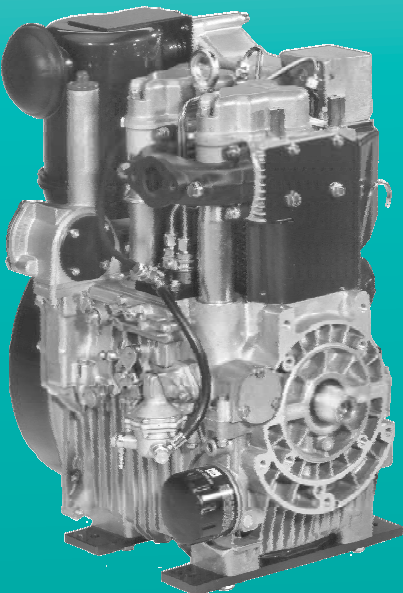

Design

- Aircooled 2-cylinder fourstroke Diesel engine.
- Vertical cylinder.
- Crankcase made of alloy, pressure diecasting, parted, vertical in-line cylinders, grey cast iron.
- Single cylinder heads of light alloy.
- Three-slide bearing crankshaft with solid-forged counterweights.
- Valve control by rocker, push-rods, tappets and camshaft.
- Pressure circulating lubrication system with replaceable filter in main flow.
- Blower fan charging alternator integrated in the flywheel, no V-belt necessary.

Characteristics

- Denoised: Due to constructional measure the noise emission has been reduced to a minimum
- All purpose industrial Diesel engine.
- Low weight due to design of alloy.
- Low fuel consumption due to direct injection and multihole nozzles.
- Favourable exhaust emission values below limits of EPA / CARB.
- Robust, and long life-engine.
- Low repair cost due to single cylinders and single cylinder heads.
- Unusual reliability - because no V-belts.
- Easy to service - automatic injection pump bleeding.
- Reliable, effortless starting thanks to automatic extra fuel device.
- Optional rope- or electric start.

Additional equipment

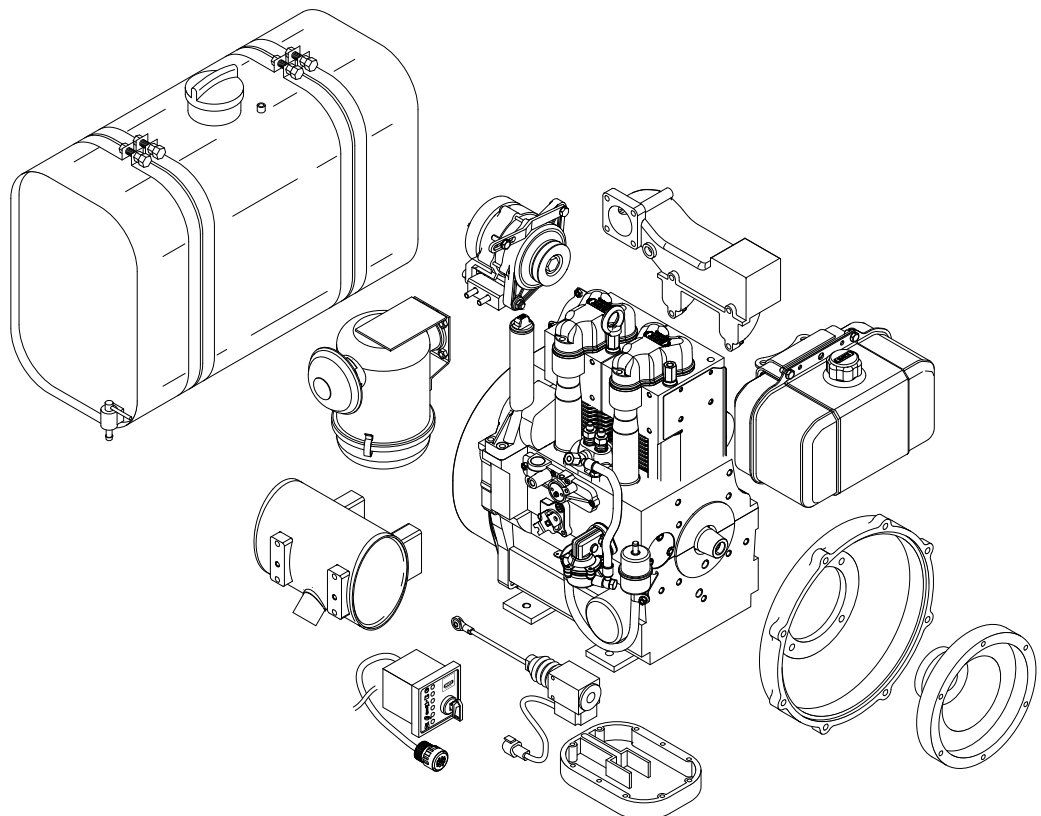

Technical data		2G40
Number of cylinders		2
Bore x stroke	mm	92 x 75
	inches	3.62 x 2.95
Displacement	l	0.997
	cu.in.	60.84
Mean piston speed at 3000 r.p.m.	m/s	7.5
	ft/min	1476.38
Compression ratio		20.5
Lub. oil consumption		approx. 1 % of fuel consumption, related to full load
Lub. oil capacity max. / min.	l	2.5 / 1.67
	US qts	2.643 / 1.765
Speed control	Idle speed	approx. 1000 r.p.m.
	Static speed droop	approx. 5 % at 3000 r.p.m.

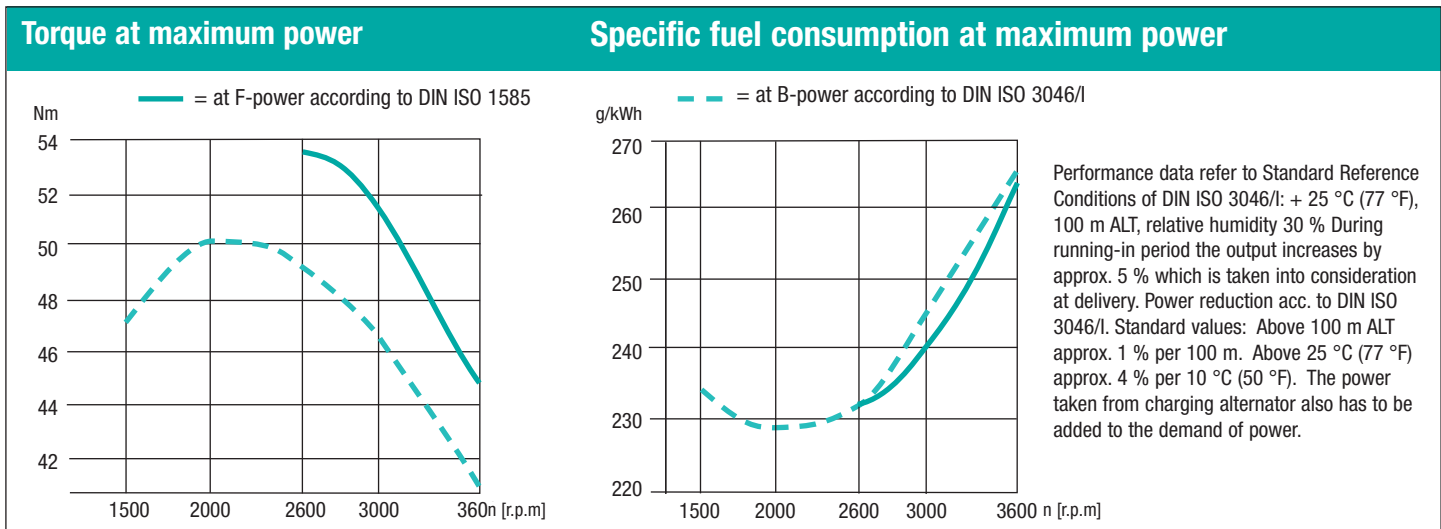

Performance table	SPECIAL OUTPUT ON REQUEST		2G40	
	Hatz-Stand.	r.p.m.	kW	HP
Vehicle output acc. to DIN ISO 1585.	F	3600	17.0	23.1
		3000	16.2	22.0
		2600	14.6	19.9
ISO net brake fuel stop power (IFN) for strong intermittent load acc. to DIN ISO 3046/I.	Bsi	3600	16.3	22.2
		3000	15.5	21.1
		2600	13.9	18.9
ISO net brake fuel stop power (IFN) for intermittent load acc. to DIN ISO 3046/I.	B	3600	15.6	21.2
		3000	14.7	20.0
		2600	13.4	18.2
		2300	12.0	16.3
		2000	10.5	14.3
		1800	9.3	12.6
		1500	7.4	10.1
ISO-standard power (ICXN) (10% overload permissible) and ISO-standard fuel stop power (no overload permissible) acc. to DIN ISO 3046/I. For constant speed and constant load (ICFN).	S	3000	13.7	18.6
		2500	12.3	16.7

Installation data		2G40
Combustion air required at 3000 r.p.m. approx. ¹⁾	m ³ / min	1.42
	cu.ft./min	50.3
Cooling air required at 3000 r.p.m. approx. ¹⁾	m ³ / min	10.5
	cu.ft./min	370
Permanent tilting	max. degrees	25 ²⁾ , 30 ³⁾ , 17 ⁴⁾ , 30 ⁵⁾
Moment of inertia	kgm ²	0.16
	lb.ft. ²	3.78
Starter		Var. XI / LI: 12 V - 2.0 kW, Var. XIII / LIII: 24 V - 3.0 kW
Alternator charging current at	3000 r.p.m.	Var. XI: 14 V - 23 A, Var. XIII: 28 V - 12 A, Var. LI: 14 V - 55 A, Var. LIII: 28 V - 27 A
	1500 r.p.m.	Var. XI: 14 V - 10 A, Var. XIII: 28 V - 5 A, Var. LI: 14 V - 55 A, Var. LIII: 28 V - 27 A
Battery capacity	min / max. Ah	12 V / 45 / 88 Ah, 24 V / 45 / 88 Ah

¹⁾ For other r.p.m. the indicated amount of air must be reduced linear accordingly ²⁾ Flywheel up ³⁾ Flywheel down ⁴⁾ Oilfilter up ⁵⁾ Oilfilter down

Permissible load on power-take-off points

Max. permissible radial load

$$F1 = \frac{261\,000}{L1 \text{ (mm)}} \text{ (N)}^{1)}$$

$$F2 = \frac{293\,000}{L2 \text{ (mm)}} \text{ (N)}^{1)}$$

¹⁾ If belt tension is upwards, valves reduced to approx. 55 %.

Max. permissible axial force

$$FA = 3400 \text{ N}$$

Transmissible torque

- A: 100 %
- B: 100 %
- C: 30.6 Nm

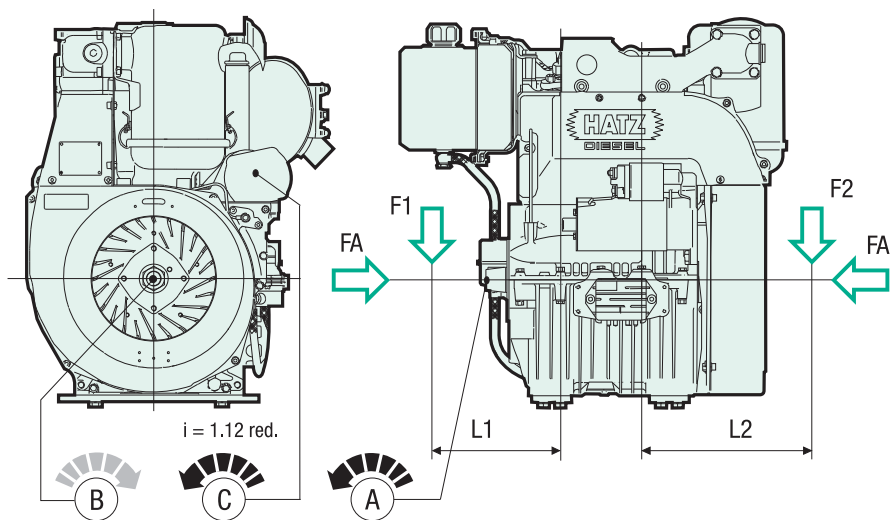

1

Maintenance and operating points

To achieve the engines' maximum life, it is essential that the engine gets serviced meticulously at regular intervals.

The better the accessibility, the more promptly and conscientiously the engine will be maintained.

Please convince yourself personally that all service and operation points are easily accessible before delivering your machine to the customer.

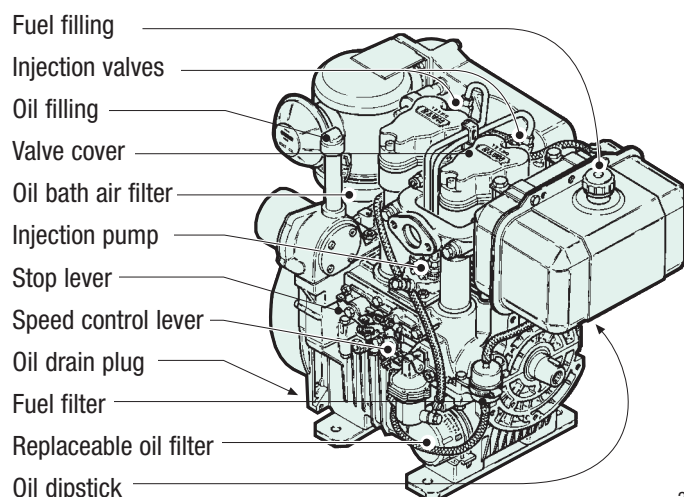

2

Electrical equipment

The engine-mounted components, such as starter, alternator and switches, are connected to the instrument box by means of a 2 m cable harness. The engine is started and controlled from this instrument box. Instrument box and cable harness are part of the additional equipment and supplied according to the number of electrical safety features which are required. If the engine has to

be started at temperatures below - 7 °C, it must be equipped with a preheating system (glow plug) (additional equipment). Further additional equipment includes automatic start and stop, remote control etc.

Please ask for drawings and wiring diagrams.

www.hatz-diesel.com

Power-Take-Off and Sense of Rotation

- Main power-take-off with engine speed at opposite side of flywheel (fig. 3).
- Power-take-off at flywheel with engine speed (fig. 4).

Engine Variants

- **Variant VI:** Rope start (fig. 5).
 - **Variant XI:** Electric start 12 V (fig. 6).
 - **Variant XIII:** Electric start 24 V (fig. 6).
 - **Variant LI:** Electric start 12 V (fig. 7).
 - **Variant LIII:** Electric start 24 V (fig. 7).
- flangeable at main p.t.o. side opposite flywheel either directly or using adaptor housing SAE 5.

Mounting of engine

For engine speeds above 2300 - 2500 r.p.m. it is recommended to use flexible mounts. On request we recommend suitable rubber mounts.

Please inform us:

- weight of unit to be supported
- position of gravity center
- selected speed

Weight incl. air filter and exhaust silencer

	Var. VI	Var. XI	Var. XIII	Var. LI	Var. LIII
kg	88.8	96.8	99.1	103.4	105.2
lbs.	195.8	213.4	218.5	228.0	232.0

Scope of delivery of engine in standard equipment

Engine completely assembled and tested for full load. Equipped with speed control, operated via Bowden cable, automatic cold start device, automatic injection pump bleeding, eye-hook for transport (capability for engine only).

Sheet metal parts black lacquered. Engine without oil.

Accessories: Gaskets for 1st maintenance

Further equipment included in engine variants:

- **Variant VI:** Starter pulley and starter rope
- **Variant XI:** Starter 12 V, 2.0 kW, Alternator a.c. 14 V, 23 A,
- **Variant XIII:** Starter 24 V, 3.0/3.5 kW, Alternator a.c. 28 V, 12 A,
- **Variant LI:** Starter 12 V, 2.0 kW, Alternator 3ph. 14 V, 55 A,
- **Variant LIII:** Starter 24 V, 3.0/3.5 kW, Alternator 3ph. 28 V, 27 A, the **Var. XI, XIII, LI, LIII** with ring gear and oil pressure switch.

Additional equipment

Thanks to the complete programme of additional equipment every engine can be adapted to the special requirements of every application.

As a minimum, every engine needs the "additional equipment necessary for operation".

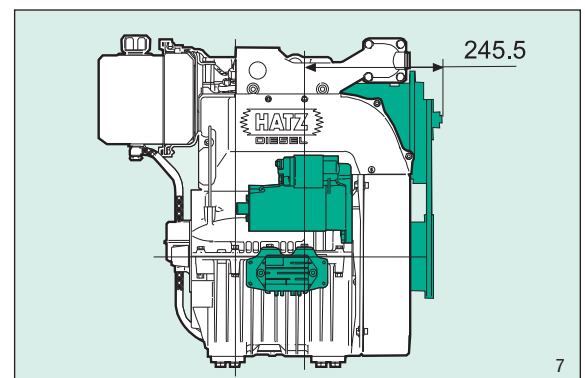
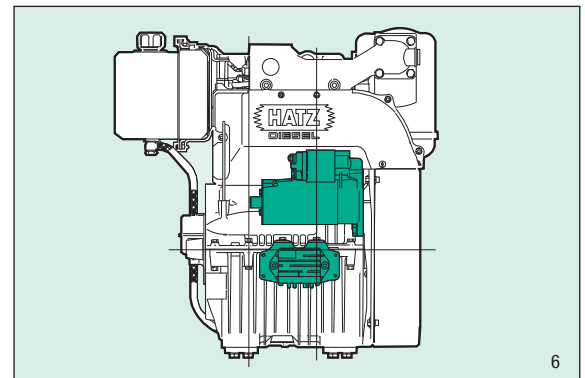
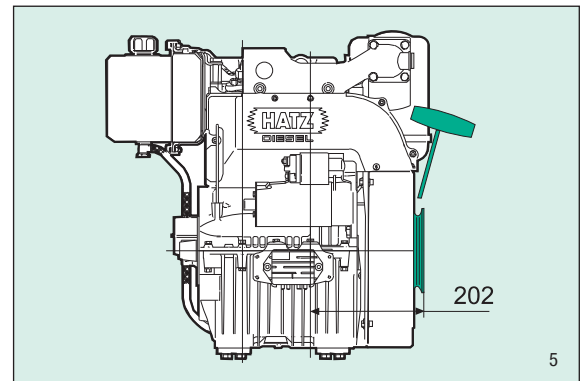
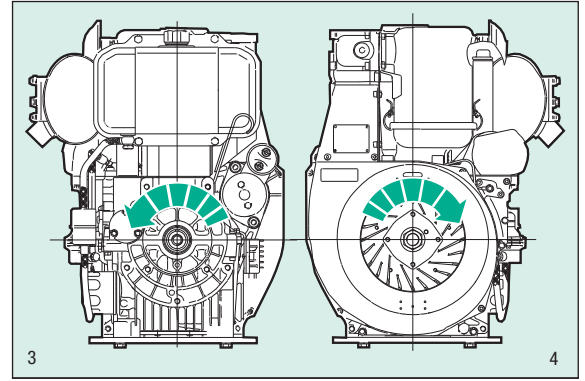

Dimensions

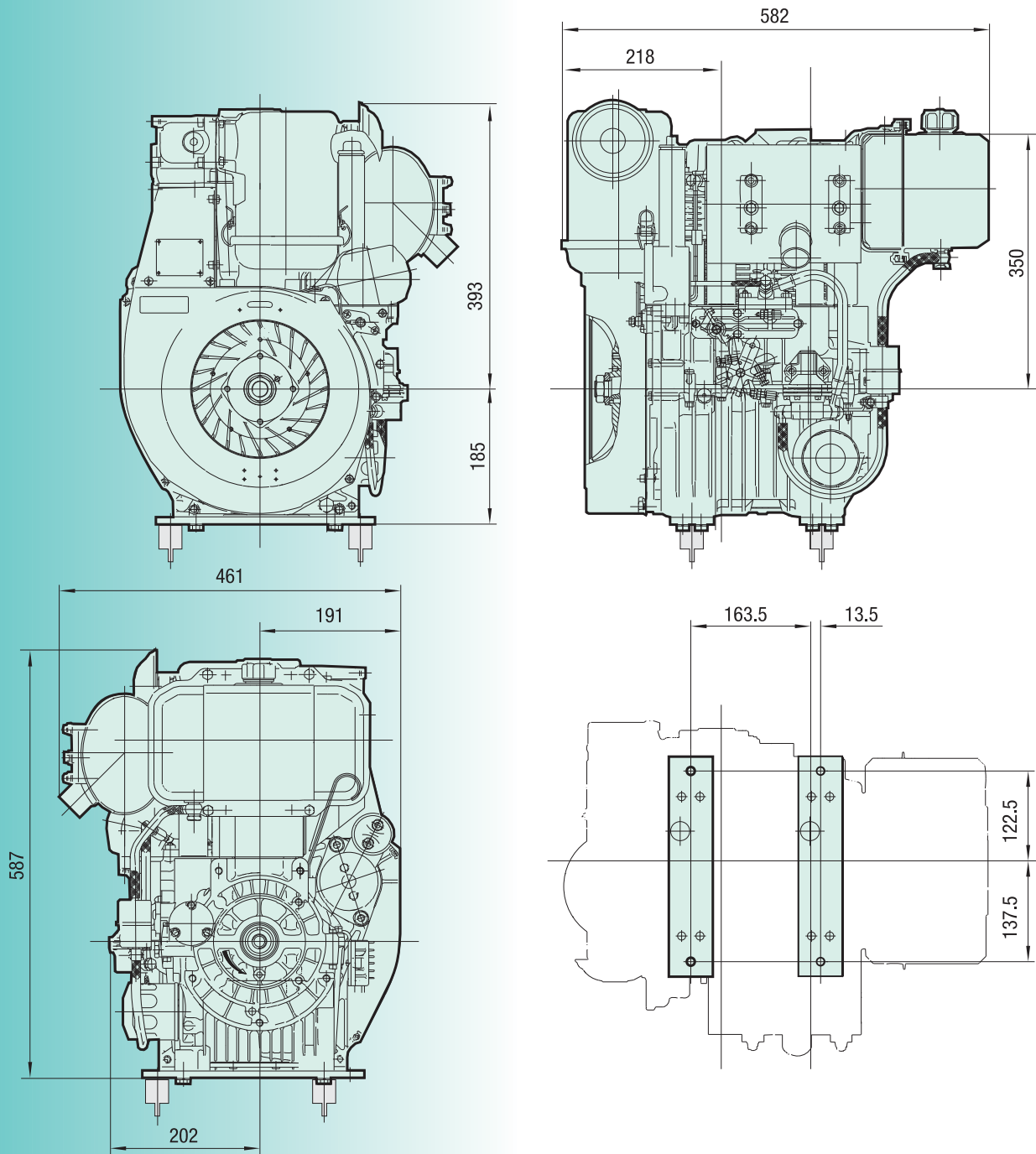

Spread at outlines ± 3 mm due to tolerance.

Drawings with detailed - and connection measures can either be demanded or downloaded as pdf- resp. dxf-file which are shown in the Internet.

**MOTORENFABRIK HATZ
GMBH & CO. KG**
Ernst-Hatz-Straße 16
D-94099 Ruhstorf
GERMANY

Telephone: +49 (0) 85 31 / 319-0
Telefax: +49 (0) 85 31 / 31 94 18
marketing@hatz-diesel.de

www.hatz-diesel.com



5 / 568 ENG - 03.07 - 1 Printed in Germany
Modifications, which serve the technical improvements, are reserved.