



D 704 LTE - 62 kW (84 CV)

Industrial Power

CARATTERISTICHE TECNICHE

TECHNICAL FEATURES

CARACTERISTIQUES TECHNIQUES

HAUPTMERKMALE

CARACTERISTICAS TECNICAS

Motore diesel 4 tempi
Iniezione Diretta
Raffreddato ad acqua
Sovralimentato

4 stroke diesel engine
Direct injection
Water cooled
Turbocharged

Moteur Diesel - 4 temps
Injection directe
Refroidissement à eau
Suralimenté

Dieselmotor - 4 takt
Direkte Einspritzung
Wasserkühlung
Turboaufgeladen

Motor Diesel - 4 tiempos
Inyeccion directa
Refrigeracion por agua
Sobrealimentado

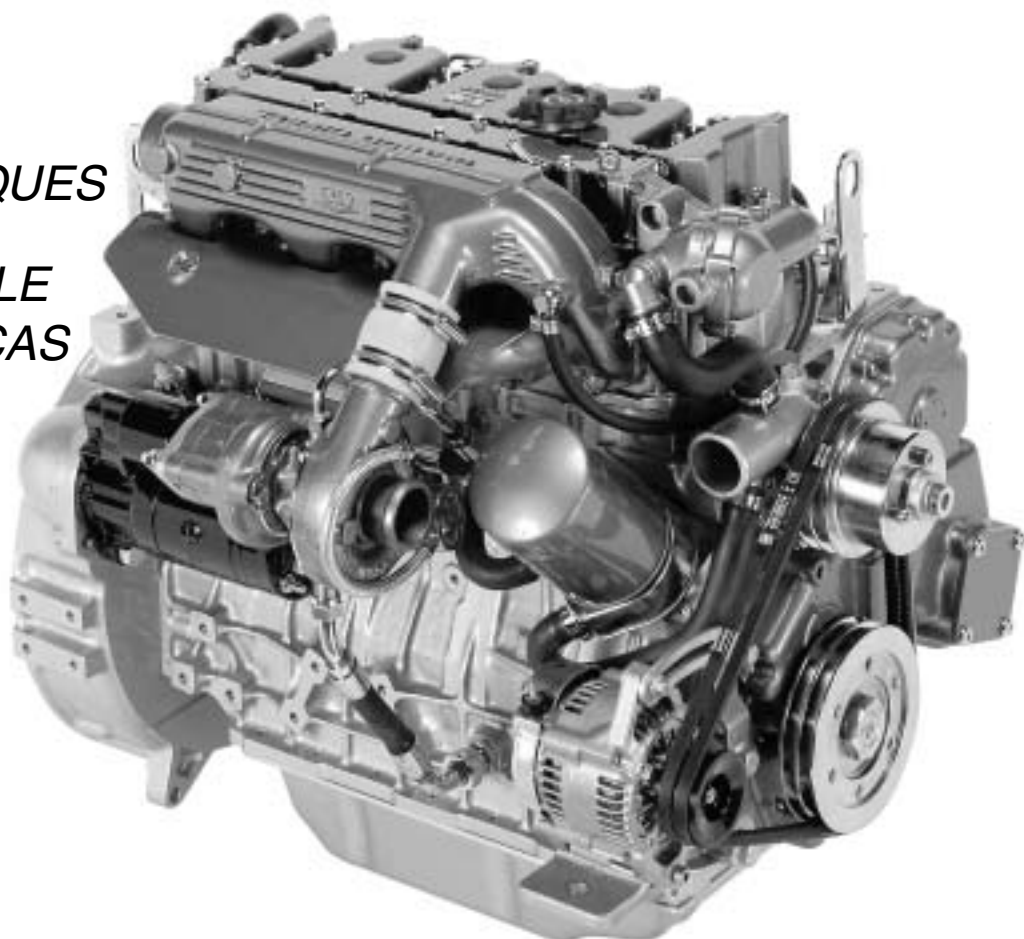

Dati Motore	Engine Data	Données Moteur	Motor Daten	Datos Motor	
Numero dei cilindri	<i>Cylinder</i>	<i>Cylindres</i>	<i>Zylinder</i>	<i>Cilindros</i>	4
Alesaggio x Corsa	<i>Bore x Stroke</i>	<i>Alesage x course</i>	<i>Bohrung x Hub</i>	<i>Diametro x carrera</i>	94 x 100 mm
Cilindrata	<i>Displacement</i>	<i>Cylindrée</i>	<i>Gesamthubraum</i>	<i>Cilindrada</i>	2,8 l
Peso a secco	<i>Dry Weight</i>	<i>Poids à sec</i>	<i>Trockengewicht</i>	<i>Peso en seco</i>	262 kg
Potenza massima	<i>Max Power</i>	<i>Puissance maximum</i>	<i>Hochstleistung</i>	<i>Potencia maxima</i>	62 kW (84 CV)
Coppia massima	<i>Max Torque</i>	<i>Couple max</i>	<i>Max Drehmoment</i>	<i>Par maximo</i>	290 Nm (30 Kgm)
Emissioni	<i>Emissions</i>	<i>Emissions</i>	<i>Emission</i>	<i>Emisiones</i>	EPA - 97 / 68 / EC

Allestimento standard	Standard equipment	Équipement standard	Standardausruestung	Equipo standard
Campana SAE 4	<i>Flywheel housing SAE 4</i>	<i>Carter volant SAE 4</i>	<i>Schwungradgehäuse SAE 4</i>	<i>Carcasa volante SAE 4</i>
Volano 8" - 10"	<i>Flywheel 8" - 10"</i>	<i>Volant 8" - 10"</i>	<i>Schwungrad 8" - 10"</i>	<i>Volante 8" - 10"</i>
Impianto elettrico 12 V	<i>12 V electric system</i>	<i>Système électrique 12V</i>	<i>Electrosystem 12V</i>	<i>Sistema eléctrico 12V</i>
Candlette di preriscaldamento	<i>Preheating glow plugs</i>	<i>Bougies de prechauffage</i>	<i>Gluehkerzen</i>	<i>Bujias</i>
Elettrostop	<i>Electrostop</i>	<i>Electrostop</i>	<i>Elektromagnet stoppen</i>	<i>Electroimán de stop</i>

La foto illustra un tipico motore industriale
Photograph shows an example of a typical industrial engine

Curve Caratteristiche
Performance Curve
Courbes Caracteristiques
Kennlinien
Curvas Caracteristicas

Potenza Intermittente
Intermittent Power
Puissance Intermittente
Kurzzeitleistung
Potencia Intermitente
ISO 3046 /1

Potenza Continua
Continuous Power
Puissance Continue
Dauerleistung
Potencia Continua
ISO 3046 /1

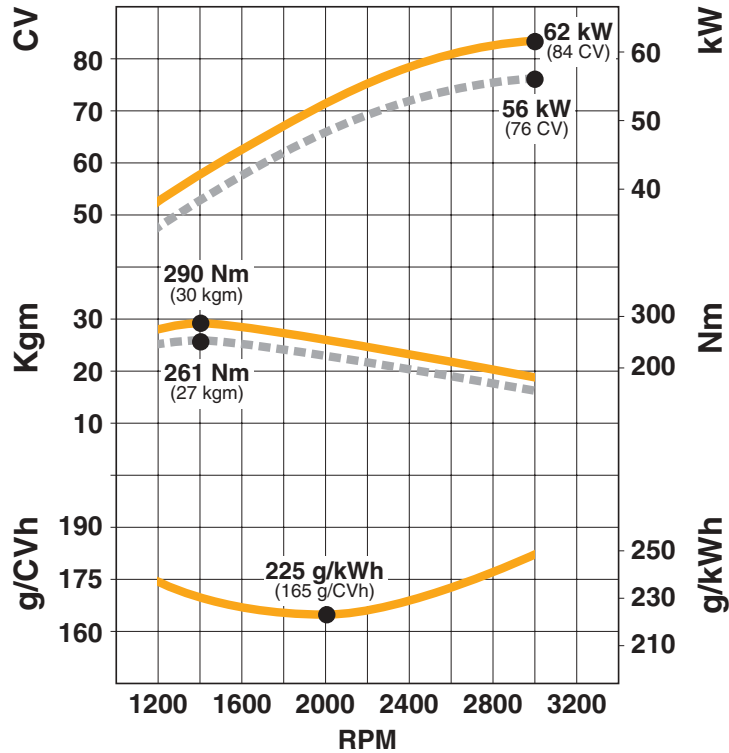

D 704 LTE

Dimensioni - Dimensions - Dimensions - Masse - Dimensiones

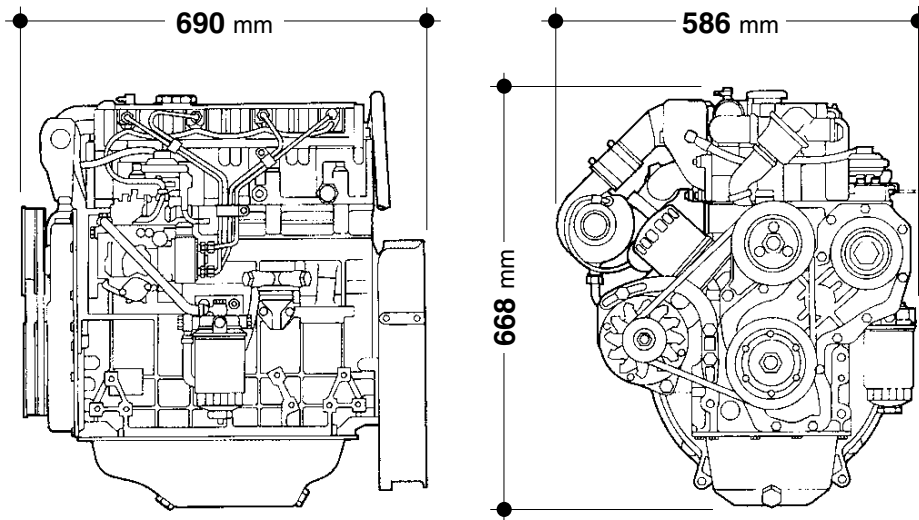

44042 CENTO (Ferrara) - Italy - Via Ferrarese, 29
 Tel. +39 - 051- 6837 511 - Fax +39 - 051- 6837 535
 www.vmmotori.it - e-mail: industrial-marine@cento.detroitdiesel.com



ISO 14001 - Cert. n° 0043A/0

Azienda di progettazione, produzione e commercializzazione di motori diesel con Sistema Qualità ed Ambiente certificato.



ISO 9001 - Cert. n° 0295/1
 QS-9000 - Cert. n° 0842/1

Company with the Quality and Environmental system certified for diesel engine design manufacturing and commercialization.

VM is registered trademark of VM MOTORI.

As technical advancements continue, specification may change. Printed in Italy - VM MOTORI Advertising Department - Cod. 4 250 2703 F - M1 - 11.'01

VM MOTORI preferisce-prefers M@bil